

LN Series LN-VAVCF Controller

Product Bulletin

Code No. LIT-12011299
 Issued May 2, 2007

The LN Series LN-VAVCF controller uses the latest technology to provide more flexibility and reliability. The LN-VAVCF controllers can be programmed very easily using any LNS® based program, such as LN Builder 3. The LN-VAVCF controller features a drift-free differential pressure sensor that resists loss of accuracy over time due to dust particle accumulation.

The LN-VAVCF controller uses the LonTalk® communication protocol and is LONMARK® certified with the Sensor profile (#1) for input object and the Actuator profile (#3) for the output objects.



Figure 1: LN VAV Controller

Table 1: Features and Benefits

Feature	Benefit
Software	Features 18 Network Variable Inputs and Outputs (NVI/NVOs) with changeable types and lengths, supports fan-in binding for zoning applications, and all objects (programming, schedule, real time clock) are configurable through their own LNS plug-in.
Hardware	Allows you to use any commercially available thermistor type (100 ohms to 100 k ohms) and setpoint potentiometer type. Features an extremely accurate on-board air flow sensor for pressure independent single duct Variable Air Volume (VAV) applications. Can read differential pressure as small as 0.04 milli-inches.
Robust Communications Protocol	Complies with LONWORKS technology for interoperability and peer-to-peer communication between controllers without the necessity of intermediary agents.
Free Programmable Object	Allows you to view all internal points using 10 UNVT and 15 values of each object. The LN-VAVCF controller offers many programming tools like Proportional plus Integral plus Derivative (PID), timers, and optimum start.

LN-VAVCF Controller Overview

The LN-VAVCF controller uses the free programmable plug-in which allows you to easily use the graphical interface with the power and flexibility of a code editor and compiler. Johnson Controls® Free Programmable Plug-in uses a unique and simplified version of BASIC that is custom-made to suit any control requirements. Through the original combination of built-in functions and an easy to use Graphical User Interface (GUI), the LN-VAVCF controller offers you the very best in modular control programming.

Software Plug-ins

The plug-ins simplify complex programming and sequencing methods by prompting users for the necessary configuration data.

Free Programmable Plug-in

The Free Programmable Plug-in is unique in the Controls industry because it combines an easy to use graphical interface with the power and flexibility of a code editor and compiler. New built-in commands have been added in the LN Series LN-VAVCF models of Free Programmable controllers, like the Square Root (SQRT) function that calculates the square root of a value.

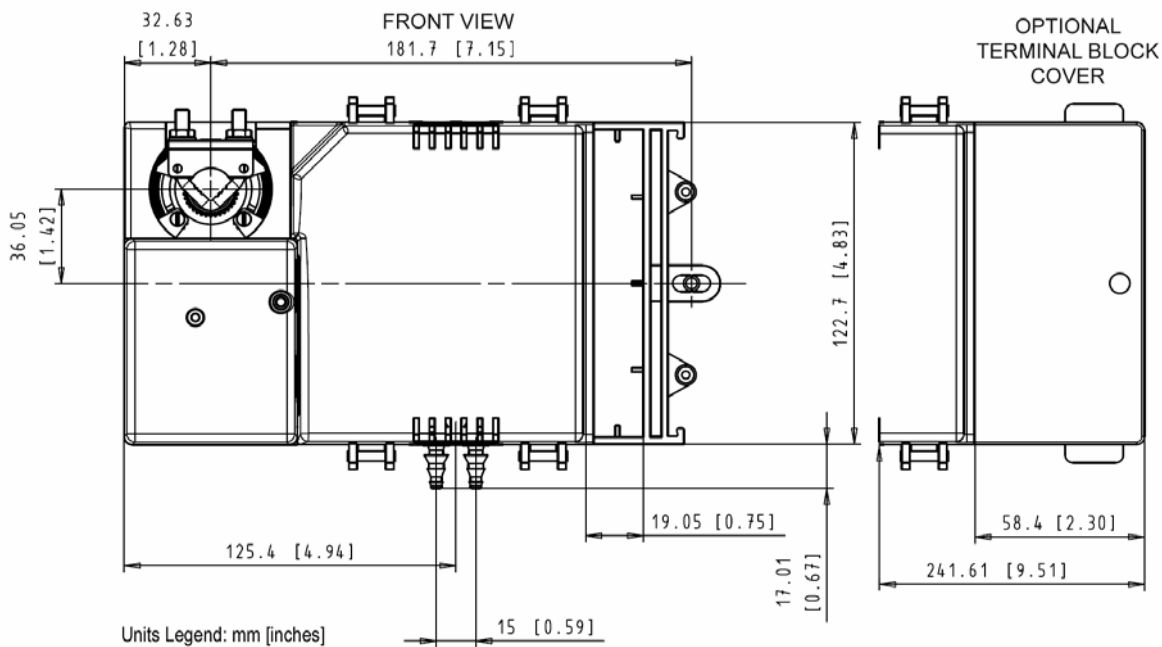

Figure 2: Dimensions, mm (in.)

LONMARK Objects and Network Variables

Figure 3 shows the LN-VAVCF LONMARK Objects and Network Variables.

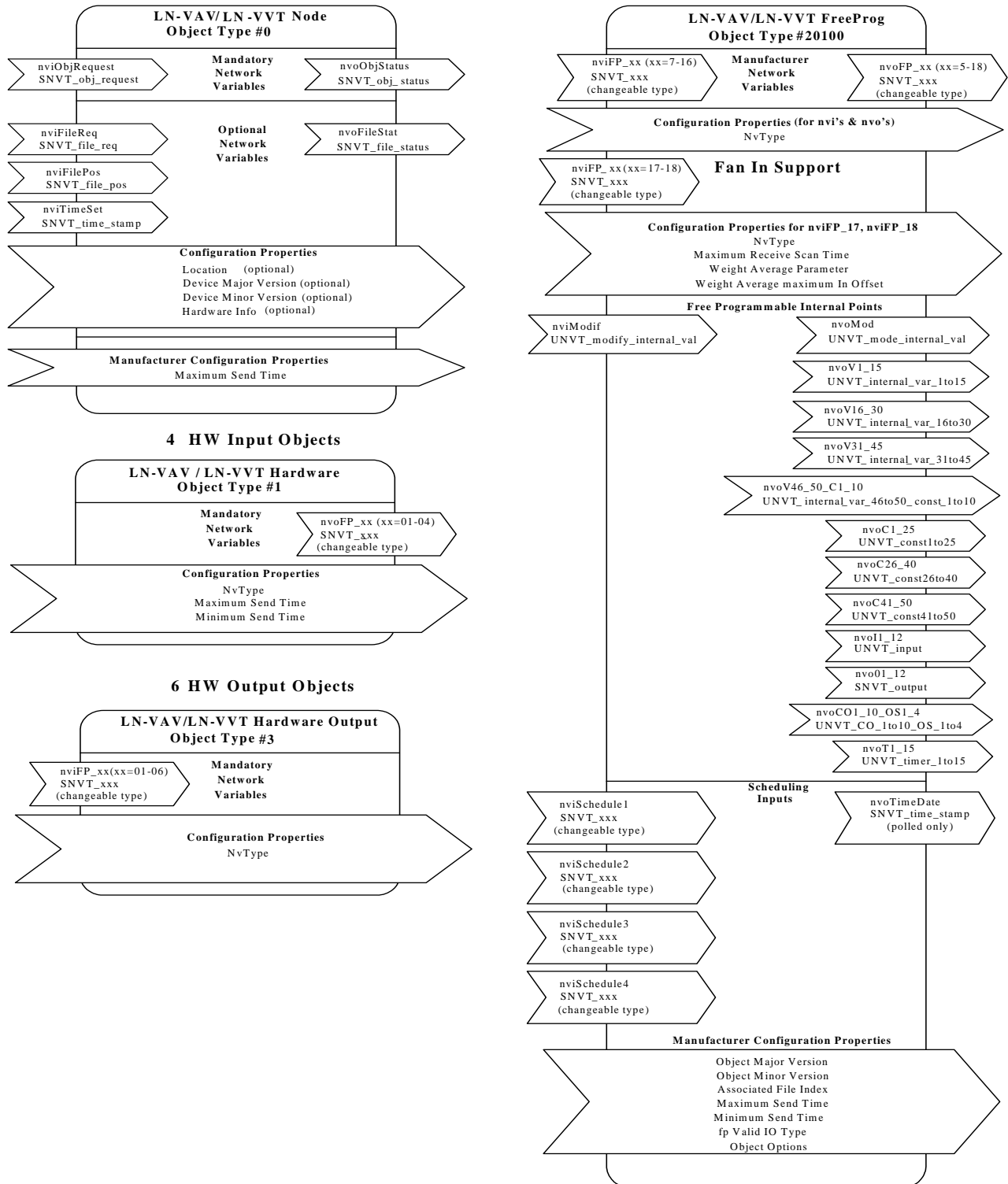

Figure 3: LONMARK Objects and Network Variables--LN-VAVCF

Technical Specifications

LN-VAVCF

Product Code	LN-VAVCF-1
Power Requirements	Voltage: 24 VAC/DC; $\pm 15\%$, 50/60 Hz, Class 2 Protection: 3A removable fuse for triac when using the internal power supply Consumption: 5 VA Maximum Consumption: 10 VA (normal), or 85 VA if internal power supply is used for triac (special application)
Ambient Storage Conditions	Ambient Operating Temperature: 0 to 70° C, (32 to 158° F) Ambient Storage Temperature: -20 to 70° C, (-4 to 158° F) Ambient Storage Conditions: 0 to 90% noncondensing
General	Processor: Neuron® 3150®, 8 bits, 10 MHz Memory: Non-volatile Flash 128k (storage) (APB application, Non-volatile Flash 64k (APB application) Media Channel: TP/FT-10, 78 Kbps Communication: LonTalk® protocol Trasnsceiver: Echelon® FTT-10
Enclosure (Housing)	Material: FR/ABS Resin Dimensions (with screws): 4.88 x 8.9 x 2.48 in. (124 x 226 x 63 mm) Shipping Weight: 2.30 lbs (1.05 kg)
Inputs	Quantity: 4 universal software configurable Input Types: Digital: Dry Contact, Analog Voltage: 0 -10 VDC, Accuracy: $\pm 0.5\%$, Analog current: 4-20 mA with 249 ohms external resistor Resistor Support: Thermistor: 100 ohms (PT100), 1 K (RTD I K Type 85), 10 K (Type, 2, 3), Range: -40 to 125° C, (-40 to 257° F) Accuracy: $\pm 0.5^\circ$ C, $\pm 0.9^\circ$ F Resolution: 0.1 to 0.18° F (10K ohms to 10K ohms supported using translation table) Potentiometer: 10k ohms or 100K ohms, translation table (21 points) Differential: Range 0-250 Pa (0-1 in. H ₂ O) Pressure Sensor (VAV model only): Resolution 0.04 milli-inches H ₂ O, Accuracy $\pm 0.3\%$ full scale Input Resolution: 16 bit analog/digital converter
Hardware Outputs	Quantity: 6 Hardware 4 Digital: Triac 0.75 AMP @ 24 VAC, External or Internal power supply 2 Universal: 0-10 VDC linear, digital 0-10 VDC linear, digital 0-12 VDC (Analog or Digital) or PWM 20 mA max, Maximum load 600 ohms Output Resolution: 10 bits digital/analog converter
Damper Actuator	Torque: 35 in-lb, 4 N·m Angle of Rotation: 95° adjustable Fits Shaft Diameter: 5/16 to 3/4 in. (8.5 to 18.2 mm) Power Supply: from controller

The performance specifications are nominal and conform to acceptable industry standard. For application at conditions beyond these specifications, consult the local Johnson Controls office. Johnson Controls, Inc. shall not be liable for damages resulting from misapplication or misuse of its products.

Federal Communication Commission (FCC) Compliance Statement

This device complies with Part 15 of the FCC Rules. Operation is subject to the following two conditions: (1) this device may not cause harmful interference, and (2) this device must accept any interference that may cause undesired operation. These limits are designed to provide reasonable protection against harmful interference when this equipment is operated in a commercial environment. This equipment generates, uses, and can radiate radio frequency energy and, if not installed and used in accordance with the instruction manual, may cause harmful interference to radio communications. Operation of this equipment in a residential area is likely to cause harmful interference, in which case the user will be required to correct the interference at his or her own expense.

Warning: Changes or modifications to this unit not expressly approved by Johnson Controls, Inc. could void the user authority to operate the equipment.

Canadian Compliance Statement

This digital apparatus does not exceed the Class A limits for radio noise emissions from digital apparatus set out in the Radio Interference Regulations of Industry Canada.

Le présent appareil numérique n'émet pas de bruits radioélectriques dépassant les limites applicables aux appareils numériques de la classe A prescrites dans le Règlement sur le brouillage radioélectrique édicté par le Industrie Canada.



Controls Group
507 E. Michigan Street
Milwaukee, WI 53202

*Metasys® is a registered trademark of Johnson Controls, Inc.
All other marks herein are the marks of their respective owners.
© 2007 Johnson Controls, Inc.*

LX Series Programmable VAV Controller

Product Bulletin

Code No. LIT-12011490

Issued June 22, 2009

The LX Series Programmable VAV controller (LX-VAVCF) uses the latest technology to provide more flexibility and reliability. The programmable Variable Air Volume (VAV) controller can be programmed very easily using Facility Explorer. The controller features a drift-free differential pressure sensor that resists loss of accuracy over time due to dust particle accumulation. The LX-VAVCF controller uses the LonTalk® communication protocol.



Figure 1: LX-VAV Controller

Table 1: Features and Benefits

Features	Benefits
Software	Features 18 Network Variable Inputs (NVIs) and Network Variable Outputs (NVOs) with changeable types and lengths, supports fan-in binding for zoning applications, and all objects (programming, schedule, real-time clock) are configurable through their own wizard.
Hardware	Allows you to use any commercially available thermistor type (100 ohm to 100 k ohm) and setpoint potentiometer type. Features an extremely accurate on-board airflow sensor for pressure independent single duct VAV applications. Can read differential pressure as small as 0.04 milli-inches of water.
Robust Communications Protocol	Complies with LONWORKS technology for interoperability and peer-to-peer communication between controllers without the necessity of intermediary agents.
Free Programmable Object	Allows you to view all internal points using 10 UNVT and 15 values of each object. The LX-VAVCF controller offers many programming tools like Proportional plus Integral plus Derivative (PID), timers, and optimum start.

LX-VAVCF Controller Overview

The LX-VAVCF controller uses the free programmable wizard, which allows you to easily use the graphical interface with the power and flexibility of a code editor and compiler. Johnson Controls® Free Programmable Wizard uses a unique and simplified version of Beginner's All-Purpose Symbolic Instruction Code (BASIC) that is custom-made to suit any control requirements. Through the original combination of built-in functions and an easy to use Graphical User Interface (GUI), the LX-VAVCF controller offers you the very best in modular control programming.

Software Wizards

The wizards simplify complex programming and sequencing methods by prompting users for the necessary configuration data.

Free Programmable Wizard

The Free Programmable Wizard is unique in the Controls industry because it combines an easy to use graphical interface with the power and flexibility of a code editor and compiler. New built-in commands have been added in the LX Series LX-VAVCF models of Free Programmable controllers, like the Square Root (SQRT) function that calculates the square root of a value.

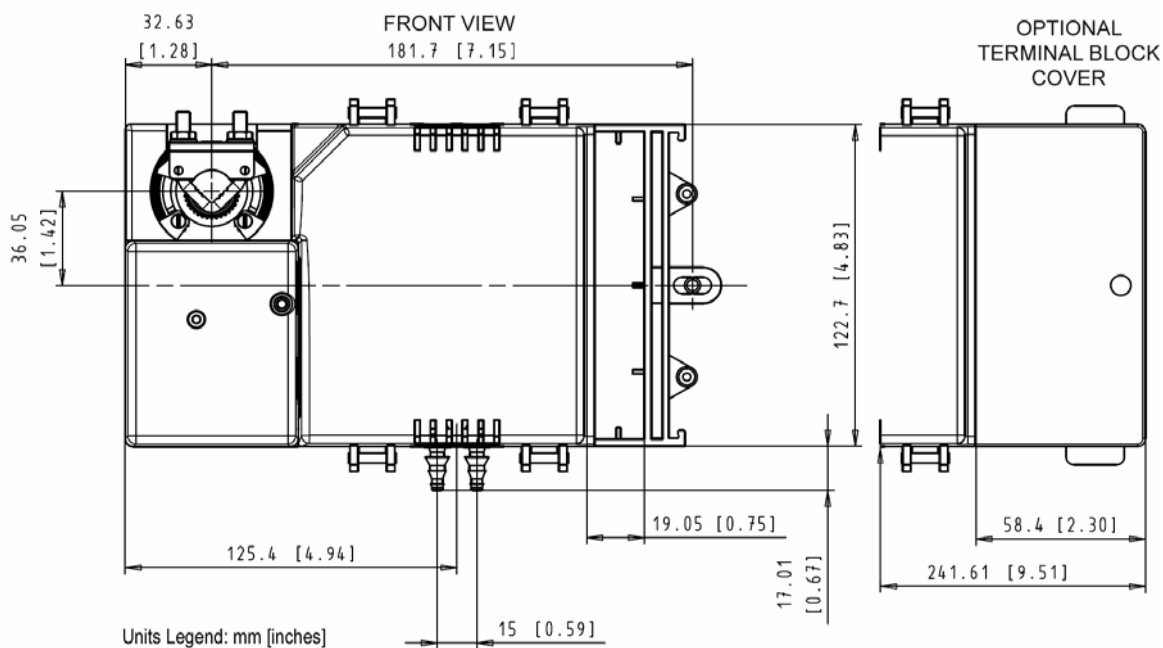

Figure 2: Dimensions, mm (in.)

Selection Chart

Table 2: Selection Chart

Code Number	Description
LX-VAVCF-1	Programmable VAV controller, actuator w/feedback, flow sensor, 10 I/O (4 Universal Inputs [UIs], 4 triac Digital Outputs [DOs], 2 Universal Outputs [UOs]) and wizard.

Repair Information

If the LX-VAVCF controller fails to operate within its specifications, replace the unit. For a replacement, contact the nearest Johnson Controls® representative.

LONMARK Objects and Network Variables

Figure 3 shows the LX-VAVCF LONMARK Objects and Network Variables.

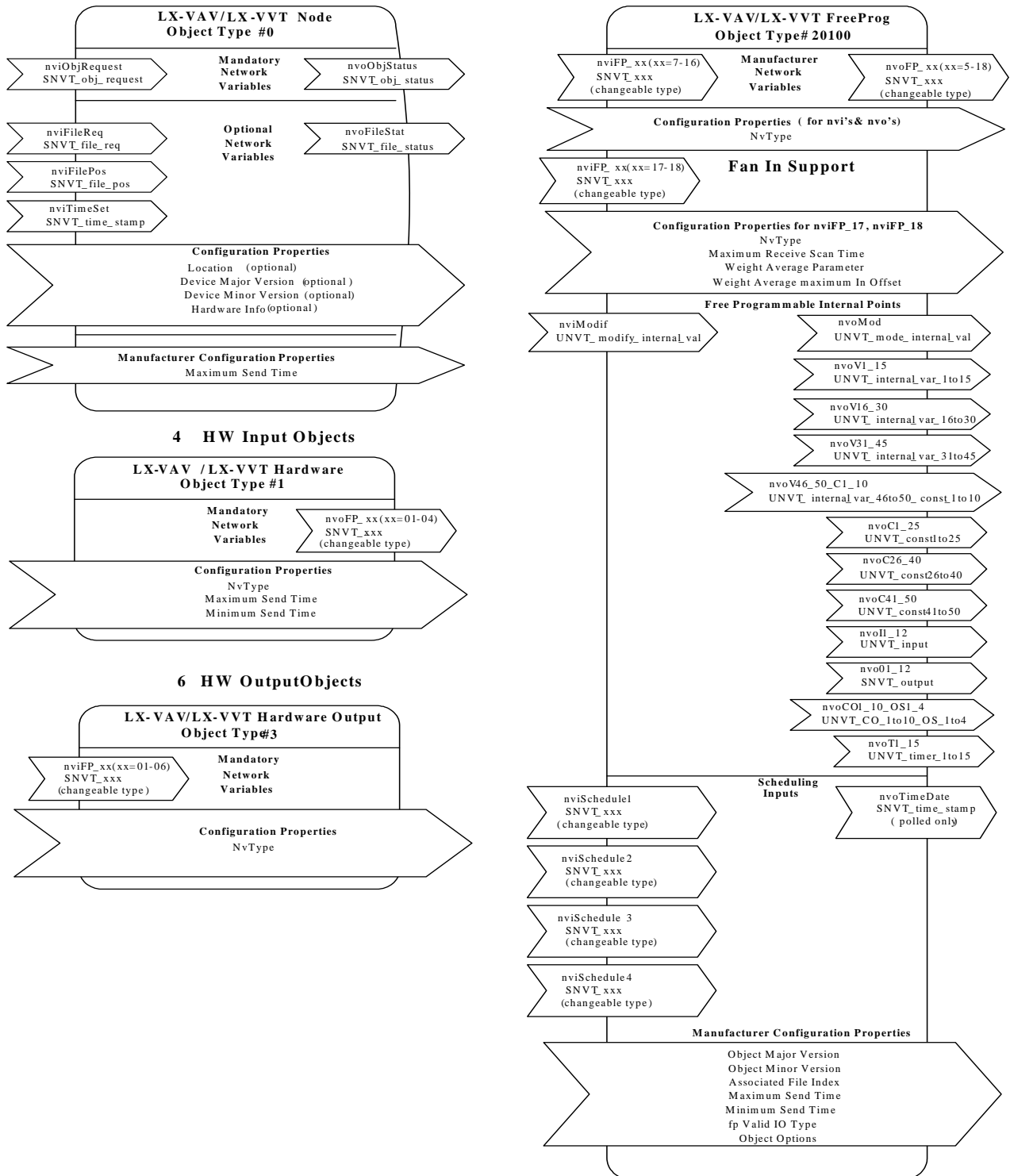

Figure 3: LONMARK Objects and Network Variables--LX-VAVCF

Technical Specifications

LX-VAVCF

Product Code	LX-VAVCF-1
Power Requirements	Voltage: 24 VAC/DC; $\pm 15\%$, 50/60 Hz, Class 2 Protection: 3A removable fuse for triac when using the internal power supply Consumption: 5 VA Maximum Consumption: 10 VA (normal), or 85 VA if internal power supply is used for triac (special application)
Ambient Conditions	Ambient Operating Temperature: 0 to 70°C, (32 to 158°F) Ambient Storage Temperature: -20 to 70°C, (-4 to 158°F) Ambient Storage Conditions: 0 to 90% noncondensing
General	Processor: Neuron® 3150®, 8 bits, 10 MHz Memory: Non-volatile Flash 128k (storage) (APB application, Non-volatile Flash 64k (APB application) Media Channel: TP/FT-10, 78 Kbps Communication: LonTalk® protocol Transceiver: Echelon® FTT-10
Enclosure (Housing)	Material: FR/ABS Resin Dimensions (with screws): 4.88 x 8.9 x 2.48 in. (124 x 226 x 63 mm) Shipping Weight: 2.30 lb (1.05 kg)
Inputs	Quantity: 4 universal software configurable Input Types: Digital: Dry Contact, Analog Voltage: 0 to 10 VDC, Accuracy: $\pm 0.5\%$, Analog current: 4 to 20 mA with 249 ohm external resistor Resistor Support: Thermistor: 100 ohm (PT100), 1 K (RTD I K Type 85), 10 K (Type, 2, Type 3), Range: -40 to 125°C, (-40 to 257°F) Accuracy: $\pm 0.5^\circ\text{C}$, $\pm 0.9^\circ\text{F}$ Resolution: 0.1 to 0.18°F (10K ohm to 10K ohm supported using translation table) Potentiometer: 10k ohms or 100K ohm, translation table (21 points) Differential: Range 0-250 Pa (0-1 in. H ₂ O) Pressure Sensor (VAV model only): Resolution 0.04 milli-inches H ₂ O, Accuracy $\pm 0.3\%$ full scale Input Resolution: 16-bit analog/digital converter
Hardware Outputs	Quantity: 6 Hardware 4 Digital: Triac 0.75 A at 24 VAC, External or Internal power supply 2 Universal: 0-10 VDC linear, digital 0-10 VDC linear, digital 0-12 VDC (Analog or Digital) or PWM 20 mA max, Maximum load 600 ohm Output Resolution: 10-bit digital/analog converter
Damper Actuator	Torque: 35 in-lb, 4 N·m Angle of Rotation: 95° adjustable Fits Shaft Diameter: 5/16 to 3/4 in. (8.5 to 18.2 mm) Power Supply: from controller

The performance specifications are nominal and conform to acceptable industry standard. For application at conditions beyond these specifications, consult the local Johnson Controls office. Johnson Controls, Inc. shall not be liable for damages resulting from misapplication or misuse of its products.

United States Emissions Compliance

This equipment has been tested and found to comply with the limits for a Class A digital device pursuant to Part 15 of the FCC Rules. These limits are designed to provide reasonable protection against harmful interference when this equipment is operated in a commercial environment. This equipment generates, uses, and can radiate radio frequency energy and, if not installed and used in accordance with the instruction manual, may cause harmful interference to radio communications. Operation of this equipment in a residential area is likely to cause harmful interference, in which case the user will be required to correct the interference at his/her own expense.

RF Transmitters: Compliance Statement (Part 15.19)

This device complies with Part 15 of the FCC Rules. Operation is subject to the following two conditions:

- 1. This device may not cause harmful interference, and*
- 2. This device must accept any interference received, including interference that may cause undesired operation.*

Warning (Part 15.21)

Changes or modifications not expressly approved by the party responsible for compliance could void the user's authority to operate the equipment.

Canadian Emissions Compliance

This Class (A) digital apparatus meets all the requirements of the Canadian Interference-Causing Equipment Regulations.

Cet appareil numérique de la Classe (A) respecte toutes les exigences du Règlement sur le matériel brouilleur du Canada.

RF Transmitters: Industry Canada Statement

The term IC before the certification/registration number only signifies that the Industry Canada technical specifications were met.

Le terme « IC » précédant le numéro d'accréditation/inscription signifie simplement que le produit est conforme aux spécifications techniques d'Industry Canada.



Building Efficiency
507 E. Michigan Street, Milwaukee, WI 53202

*Johnson Controls® is a registered trademark of Johnson Controls, Inc.
All other marks herein are the marks of their respective owners. © 2009 Johnson Controls, Inc.*