

LTEC Fan Coil Unit Controller

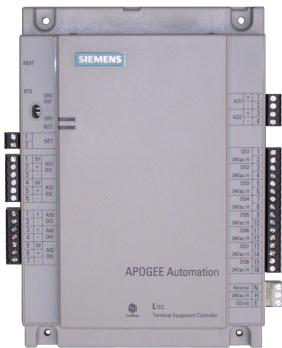

Description

The LonMark[®]-compliant LTEC[™] Fan Coil Unit (FCU) Controllers provide direct digital control of fan coil units. The LTEC FCU Controller is designed to reside on the Siemens Building Technologies, Inc. APOGEE[®] LonWorks[®] network, providing seamless interaction with all LonMark products. The LTEC offers cost-effective flexibility by allowing selection of the best point-configuration platform to meet any FCU application requirement

Features

- Conforms to the LonMark inter-operability guidelines, enabling information sharing with other LonMark products
- LonMark-compliant with Space-Comfort Controller functional profile number 8501
- Field-selectable parameters allow entry and updating of set point and control parameters via the APOGEE Interface
- Network-wide monitoring and commanding from the Room Sensor and/or LTEC controller

- LTEC offers two I/O platform styles for cost-effective selection to meet your application needs
- Advanced PID control minimizes offset and maintains tighter set-point control
- Return from power failure without operator intervention

Applications

The LTEC FCU Controller can be configured to control a variety of fan-coil unit applications, including:

- Fan coil cooling only
- Fan coil heating only
- Two-pipe fan coil unit shared cooling / heating
- Four-pipe fan coil unit cooling and heating
- Fan coil unit 1 to 2 stage cooling and electric heat or hot water heat

The LTEC FCU Controller can control perimeter heat in addition to any of the above configurations.

Additionally, based upon availability of input and output capacity and occupancy sensors can be controlled via these applications.

Hardware

Controller Board

The LTEC Controller Board is available in the following styles:

- 4 Inputs, 6 Digital Outputs, 1 Room Sensor port
- 5 Inputs, 8 Digital Outputs, 2 Analog Outputs, 1 Room Sensor port

The Controller Board is a Neuron-based platform that executes a zone level application and allows communication to all LonMark devices. The controllers are shipped with pre-loaded applications reducing engineering start-up time.

Room Sensor Port

The room sensor connection to the Controller Board consists of a quick-connect RJ-11 jack. This streamlines installation and reduces LTEC start-up time.

Spare Input/Output Points

The LTEC controller, depending upon the application used, may have up to 3 input and 2 output spare points available. These points can be used to perform local connection and network control for devices located in close proximity to the LTEC controller, therefore reducing costs associated with installation.

Specifications

Specification	
Processor Type	Neuron 3150
Processor Clock Speed	10 MHz - Neuron
Network Communication	TP/XF-10 (78.8K bps)
Memory Size	49 K Flash Memory 10 K SRAM
Local Network Communication Interface	Lon port
Voltage Requirements	24 Vac @ 50/60 Hz
Power Consumption	5 VA plus loads
Ambient Operating Environment	+32°F to +122°F (0°C to +50°C) 5 to 95% RH (Non-condensing)
Agency Listings	UL/CUL 916 PAZX/PAZX7 (Enclosed Energy Management)
Regulatory Compliance	FCC Part 15, Class B CISPR 22 Class B CE Mark
LTEC Dimensions:	8.78" H x 6.94" W x 1.85" D (223 mm x 176 mm x 47 mm)
Weight	1.13 LBS (.51 kg)

Wiring Recommendations

Input/AO	20 to 22 AWG
DO	18 to 22 AWG
Power	16 to 18 AWG
LonWorks Network	22 AWG Level IV per NEMA standards

Transformer Requirements and Recommended Voltages

Type	Class 2, 24 VAC, 50/60 Hz
------	---------------------------

Ordering Information

Controllers

Description	Product Number
LTEC CH/HW FCU Controller 4IN 6DO 4 IN (2) 100 K Ω Thermistor or Dry Contact/ (2) 0-10 Vdc, 4-20 mA or Dry Contact 6 DO 24 Vac, 12VA, Triac 1 RS 10 K Ω Thermistor Room Sensor Module	550-534
LTEC DX FCU Controller 4IN 6DO 4 IN (2) 100 K Ω Thermistor or Dry Contact/ (2) 0-10 Vdc, 4-20 mA or Dry Contact 6 DO 24 Vac, 12VA, Triac 1 RS 10 K Ω Thermistor Room Sensor Module	550-535
LTEC CH/HW FCU Controller 5IN 8DO 2AO 5 IN (2) 100 K Ω Thermistor or Dry Contact/ (3) 0-10 Vdc, 4-20 mA or Dry Contact 8 DO 24 Vac, 12VA, Triac 2 AO 0-10 Vdc 1 RS 10 K Ω Thermistor Room Sensor Module	550-536
LTEC DX FCU Controller 5IN 8DO 2AO 5 IN (2) 100K Ω Thermistor or Dry Contact/ (3) 0-10 Vdc, 4-20 mA or Dry Contact 8 DO 24 Vac, 12VA, Triac 2 AO 0-10 Vdc 1 RS 10 K Ω Thermistor Room Sensor Module	550-537
Documentation	Product Number
LTEC Owners Manual	550-311
LonWorks for APOGEE Library CD	550-312

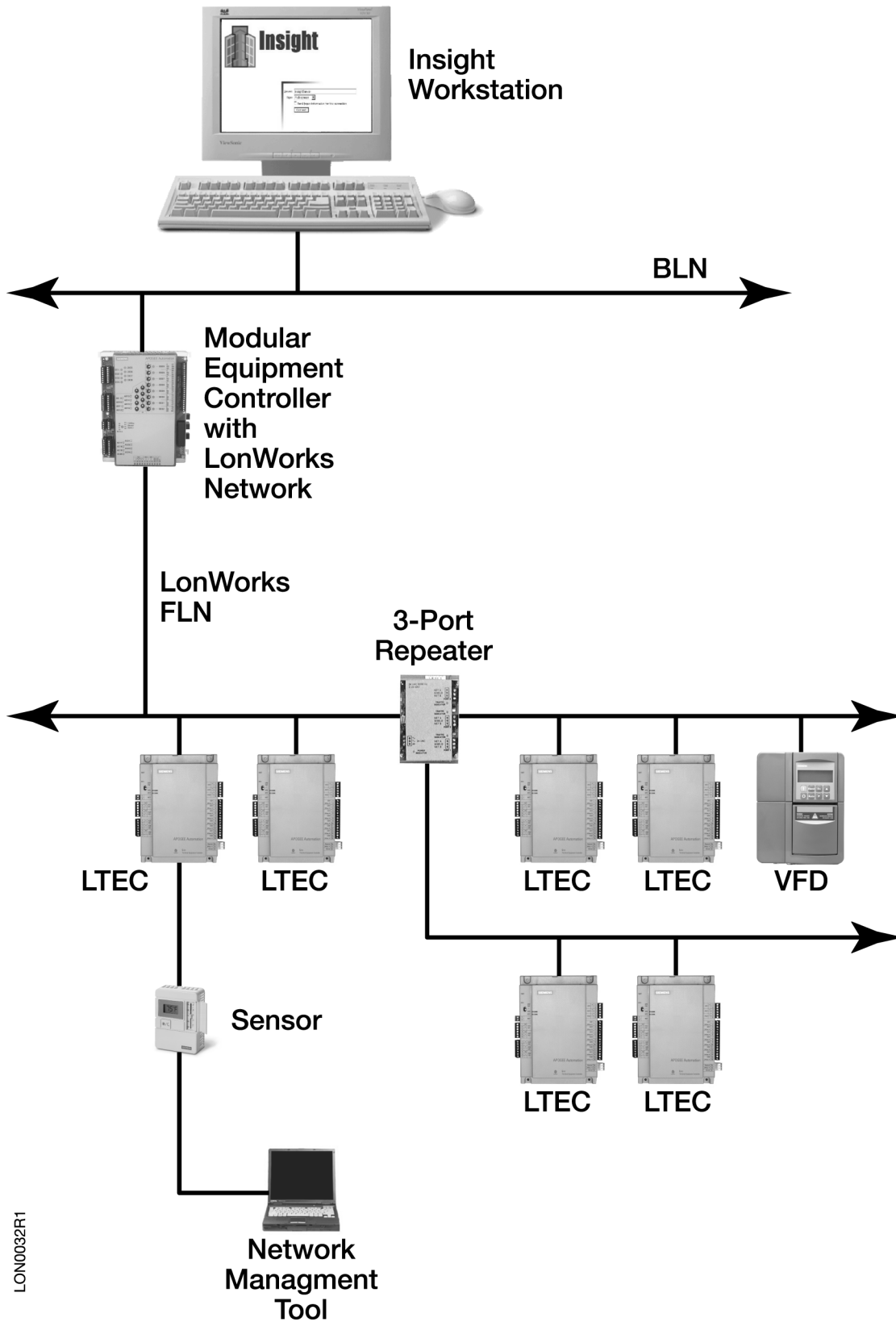

LON0032R1

Information in this document is based on specifications believed correct at the time of publication. The right is reserved to make changes as design improvements are introduced. APOGEE is a registered trademark of Siemens Building Technologies, Inc, LonMark, LonWorks and LonTalk are registered trademarks of Echelon Corporation. © 2002 Siemens Building Technologies, Inc.